

B005, Rev. -

1. Finish Goods PKG photo

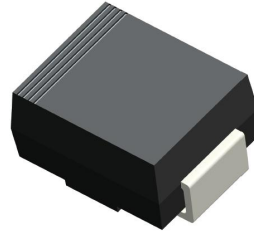

2. Packing method

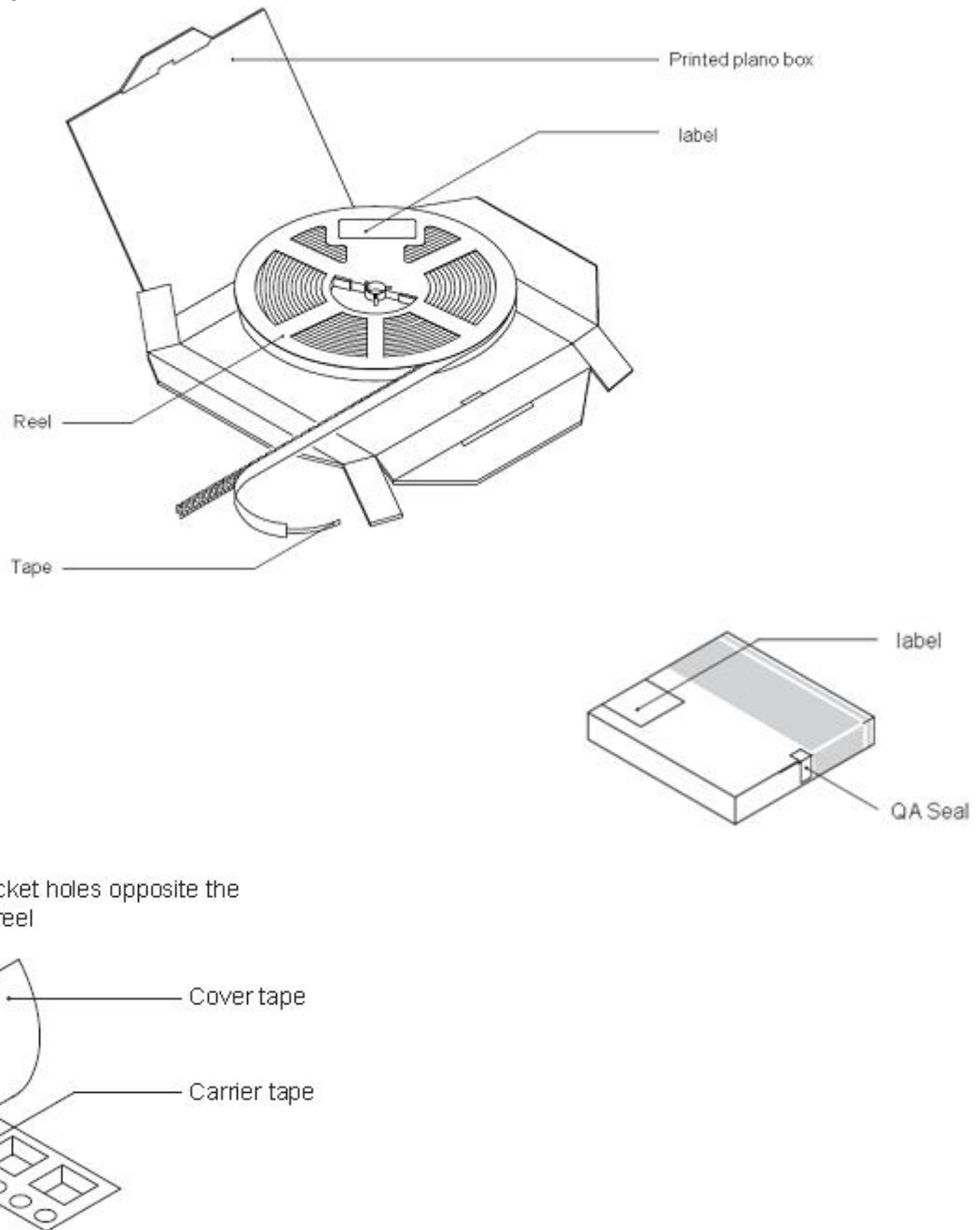

Fig.1- Reel pack for SMD

Table 1. Packing information

Package version	Reel dimensions $\phi \times H$ (mm)	Per reel (Pcs)	Reel Weight (Kg)	Inner box (pcs)	Inner box dimensions L×W×H (mm)	Inner box weight (Kg)	Outer box (pcs)	Inner box dimensions L×W×H (mm)	Outer box weight (Kg)
SMB	$\Phi 330 \times 16.8$	3000	0.56	6000	335×335×30	1.3	48000	400×360×370	11.5

3. Product orientation

Standard product orientation SMB

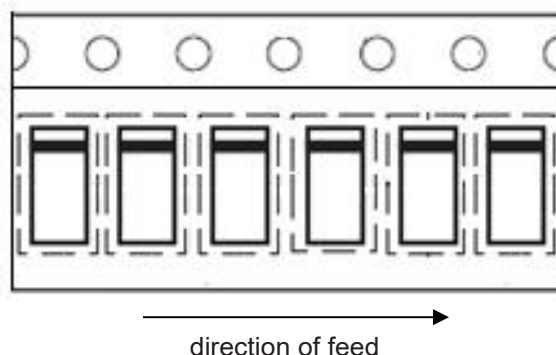

Fig 2. Product orientation in carrier tape

3. Carrier tape dimensions

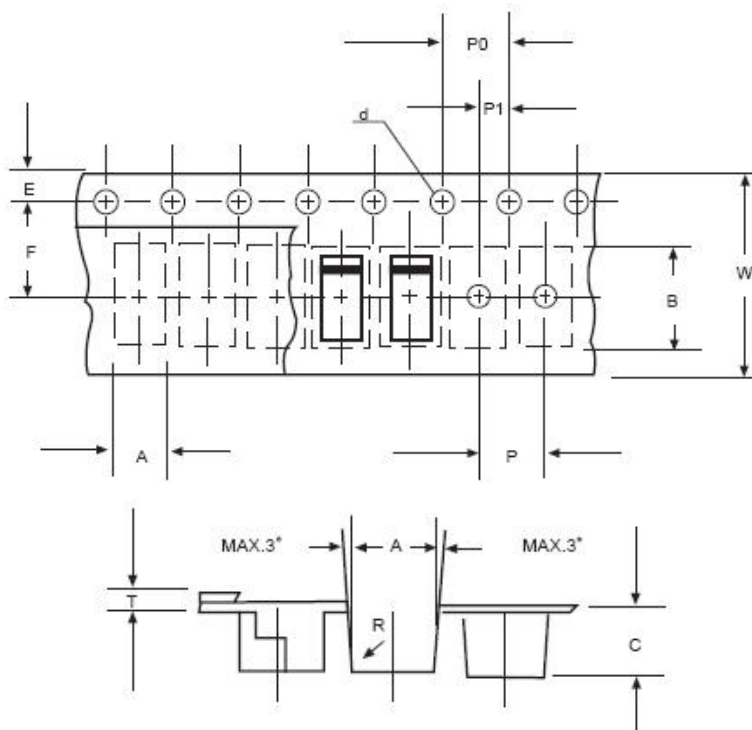

Fig 3. Carrier tape dimensions

## 4. Reel dimensions

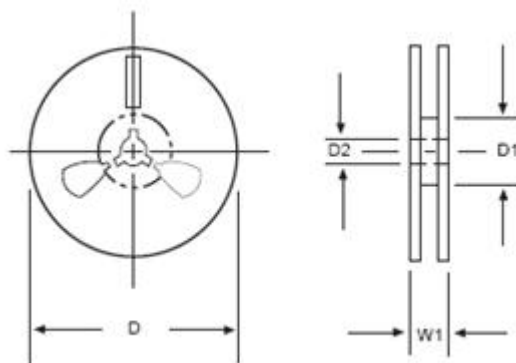

Fig 4. Reel dimensions

Table 2. Carrier tape dimensions

ITEM	SYMBOL	DO214AA (SMB) mm(inch)
Carrier width	A	$4.09 \pm 0.1 (0.161 \pm 0.004)$
Carrier length	B	$5.82 \pm 0.1 (0.229 \pm 0.004)$
Carrier depth	C	$3.33 \pm 0.1 (0.131 \pm 0.004)$
Sprocket hole	d	$1.5 \pm 0.1 (0.059 \pm 0.004)$
Reel outside diameter	D	$330 \pm 2.0 (13 \pm 0.79)$
Reel inner diameter	D1	$8.0 \pm 0.2 (0.315 \pm 0.008)$
Feed hole diameter	D2	$13 \pm 0.5 (0.301 \pm 0.002)$
Sprocket hole position	E	$1.5 \pm 0.1 (0.059 \pm 0.004)$
Punch hole position	F	$5.65 \pm 0.05 (0.222 \pm 0.002)$
Punch hole pitch	P	$8.0 \pm 0.1 (0.315 \pm 0.004)$
Sprocket hole pitch	P0	$4.0 \pm 0.1 (0.157 \pm 0.004)$
Embossment center	P1	$2.0 \pm 0.1 (0.079 \pm 0.004)$
Total tape thickness	T	0.6MAX
Tape width	W	$12.0 \pm 0.2 (0.472 \pm 0.008)$
Reel width	W1	$16.8 \pm 2.0 (0.661 \pm 0.079)$